

ISD1810

Single-Chip, Single-Message Voice Record/Playback Device 8- to 16-Second Durations

Advance Information

GENERAL DESCRIPTION

Information Storage Devices' ISD1810 ChipCorder® provides high-quality, single-chip, single-message, record/playback solution with user-selectable durations of 8 to 16 seconds. The CMOS devices include an on-chip oscillator (with external control), microphone preamplifier, automatic gain control, anti-aliasing filter, multilevel storage array, smoothing filter, and speaker amplifier. A minimum record/playback subsystem can be configured with a microphone, a speaker, several passive components, two push-buttons, and a power source.

Recordings are stored in on-chip nonvolatile memory cells, providing zero-power message storage. This unique, single-chip solution is made possible through ISD's patented multilevel storage technology. Voice and audio signals are stored directly into memory in their natural form, providing high-quality, solid-state voice reproduction.

Figure: ISD1810 Block Diagram

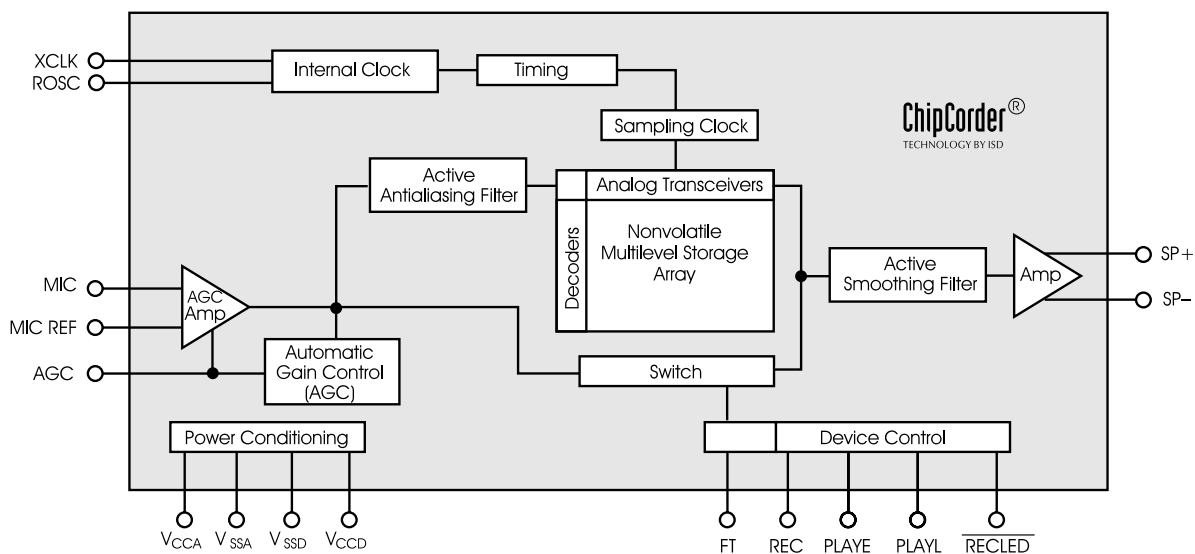

FEATURES

- Easy-to-use single-chip, single-message voice record/playback solution
- High-quality, natural voice/audio reproduction
- Push-button interface
 - Playback can be edge- or level-activated
- Variable record/playback duration controlled by external resistor selection which sets sample rate.
 - 8 KHz sample rate = 8 seconds
 - 6.4 KHz sample rate = 10 seconds
 - 5.3 KHz sample rate = 12 seconds
 - 4.0 KHz sample rate = 16 seconds
- Automatic power-down mode
 - Enters standby mode immediately following a record or playback cycle
 - 0.5 μ A standby current (typical)
- On-chip 8 Ω speaker driver
- Zero-power message storage
 - Eliminates battery backup circuits
- 100-year message retention (typical)
- 10,000 record cycles (typical)
- On-chip oscillator
- No algorithm development required
- Single +3 volt power supply
- Available in die form and 28-pin 600 mil DIP (for sampling only)

Part Number	Minimum Duration ¹ (Seconds)	Maximum Input Sample Rate (KHz) ¹	Typical Filter Upper Pass Band (KHz) ¹
ISD1810	10	6.4	2.6

NOTE A resistor value of 100 K Ω at the ROOSC pin provides this specified duration. Only this duration is guaranteed and tested.

Table of Contents

DETAILED DESCRIPTION	1
Speech/Sound Quality	1
Duration	1
NONVOLATILE Storage	1
Basic Operation	1
Automatic Power-Down Mode	1
PIN DESCRIPTIONS	1
Voltage Supplies (V_{CCA} , V_{CCD})	1
Ground Supplies (V_{SSA} , V_{SSD})	1
Record (REC)	1
Playback, Edge-Activated (PLAYE)	2
Playback, Level-Activated (PLAYL)	2
Record LED Output ($\overline{\text{RECLED}}$)	2
Microphone Input (MIC)	2
Microphone Reference (MIC REF)	2
Automatic Gain Control (AGC)	2
Speaker Outputs (SP+, SP-)	3
External Clock (XCLK)	3
Resistor Controlled Oscillator (ROSC)	3
Feed Through (FT)	3
SPECIFICATIONS	3
FUNCTIONAL DESCRIPTION EXAMPLE	6
TIMING DIAGRAMS	8
PHYSICAL DIMENSIONS	11
ORDERING INFORMATION	14

DETAILED DESCRIPTION

SPEECH/SOUND QUALITY

ISD's patented ChipCorder technology provides natural record and playback. The input voice signals are stored directly in nonvolatile cells and are reproduced without the synthetic effect often heard with digital solid-state speech solutions. A complete sample is stored in a single cell, minimizing the memory necessary to store a single message.

DURATION

The ISD1810 devices offer single-chip solutions with 8 to 16 seconds of record/playback duration capacity. Sampling rate and duration are determined by an external resistor connected to the ROSC pin. These specifications apply with the required resistor value for 10-second minimum playback duration.

NOTE *Only the 10 second duration is guaranteed and tested.*

NONVOLATILE STORAGE

One of the benefits of ISD's ChipCorder technology is the use of on-chip nonvolatile memory, providing zero-power message storage. The message is retained for up to 100 years without power. In addition, the device can be re-recorded typically over 10,000 times.

BASIC OPERATION

The ISD1810 ChipCorder device is controlled by the REC pin, and either of two playback pins, PLAYE (edge-activated playback), and PLAYL (level-activated playback). The ISD1810 parts are configured for design simplicity in a single-message application. Device operation is explained on "Functional Description Example" on page 6.

AUTOMATIC POWER-DOWN MODE

At the end of a playback or record cycle, the ISD1810 device automatically returns to a low-power standby mode, consuming typically 0.5 μ A, provided that Play REC, XCLK, and FT pins are LOW (see DC parameters). During a playback cycle, the device powers down automatically at the end of the message. During a record cycle, the device powers down immediately after REC is released LOW.

PIN DESCRIPTIONS

VOLTAGE SUPPLIES (V_{CCA} , V_{CCD})

Analog and digital circuits internal to the ISD1810 device use separate power buses to minimize noise on the chip. These power buses are brought out to separate pins on the package and should be tied together as close to the supply as possible. It is important that the power supply be decoupled as close as possible to the package.

GROUND SUPPLIES (V_{SSA} , V_{SSD})

Similar to V_{CCA} and V_{CCD} , the analog and digital circuits internal to the ISD1810 device use separate ground buses to minimize noise. These pins should be tied together as close as possible to the device.

RECORD (REC)

The REC input is an active-HIGH record signal. The device records whenever REC is HIGH. This pin must remain HIGH for the duration of the recording. REC takes precedence over either playback (PLAYL or PLAYE) signal. If REC is pulled HIGH during a playback cycle, the playback immediately ceases and recording begins.

NOTE *The REC signal is internally debounced on the rising edge to prevent a false re-triggering from a push-button switch.*

A record cycle is completed when REC is pulled LOW. An end-of-message (EOM) marker is internally recorded, enabling a subsequent playback cycle to terminate appropriately. The device automatically powers down to standby mode when REC goes LOW. This pin has an internal pull-down device. Holding this pin HIGH will increase standby current consumption.

PLAYBACK, EDGE-ACTIVATED (PLAYE)

When a HIGH-going transition is detected on this input pin, a playback cycle begins. Playback continues until an End-of-Message (EOM) marker is encountered or the end of the memory space is reached. Upon completion of the playback cycle, the device automatically powers down into standby mode. Taking PLAYE LOW during a playback cycle will not terminate the current cycle. This pin has an internal pull-down device. Holding this pin HIGH will increase standby current consumption.

PLAYBACK, LEVEL-ACTIVATED (PLAYL)

When this input pin transitions from LOW to HIGH, a playback cycle is initiated. Playback continues until PLAYL is pulled LOW, an end-of-message marker is detected, or the end of the memory space is reached. The device automatically powers down to standby mode upon completion of the playback cycle. This pin has an internal pull-down device. Holding this pin HIGH will increase standby current consumption.

RECORD LED OUTPUT (RECLE \overline{D})

The RECLE \overline{D} output is LOW during a record cycle. It can be used to drive an LED to provide feedback that a record cycle is in progress. In addition, RECLE \overline{D} pulses LOW momentarily when an end-of-message or end-of-memory marker is encountered in a playback cycle.

MICROPHONE INPUT (MIC)

The microphone input transfers its signal to the on-chip preamplifier. An on-chip Automatic Gain Control (AGC) circuit controls the gain of the

preamplifier. An external microphone should be AC coupled to this pin via a series capacitor. The capacitor value, together with the internal 10 K Ω resistance on this pin, determine the low-frequency cutoff for the ISD1810 passband.

MICROPHONE REFERENCE (MIC REF)

The MIC REF input is the inverting input to the microphone preamplifier. This provides input noise-cancellation, or common-mode rejection, when the microphone is connected differentially to the device.

Figure 1: ISD1810 Pinouts—For Sampling Only

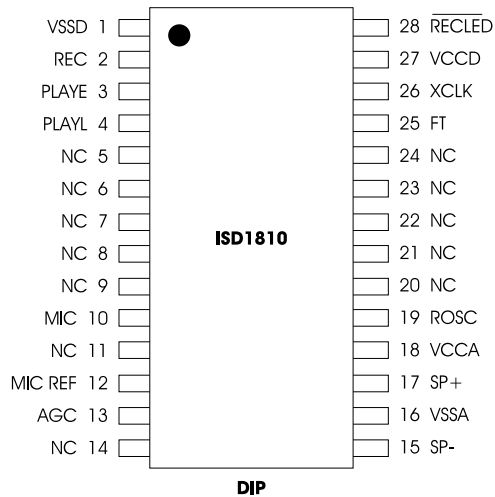

NOTE: NC means must Not Connect.

AUTOMATIC GAIN CONTROL (AGC)

The AGC dynamically adjusts the gain of the preamplifier to compensate for the wide range of microphone input levels. The AGC allows the full range of sound, from whispers to loud sounds, to be recorded with minimal distortion. Nominal values of 4.7 μ F give satisfactory results in most cases.

SPEAKER OUTPUTS (SP+, SP-)

The SP+ and SP- pins provide direct drive for loudspeakers with impedances as low as 8 Ω . A single output may be used, but, for direct-drive loudspeakers, the two opposite-polarity outputs provide an improvement in output power of up to four times over a single-ended connection. Furthermore, when SP+ and SP- are used, a speaker coupling capacitor is not required. A single-ended connection will require an AC-coupling capacitor between the SP pin and the speaker.

The SP+ pin and the SP- pin are internally connected through a 50 K Ω resistance. When not in playback mode, they are floating.

EXTERNAL CLOCK (XCLK)

The external clock input for the ISD1810 devices has an internal pull-down resistor. This pin is used for test purposes only. Do not bond this pad.

RESISTOR CONTROLLED OSCILLATOR (ROSC)

The resistor controlled oscillator input enables the user to vary the ISD1810 device record and playback duration. The resistor connected between the ROSC pin and V_{SS} (R2) determines the sample frequency and the filter upper pass band for the ISD1810 device. ISD recommends an ROSC resistor value of 100 K Ω .

FEED THROUGH (FT)

Feed Through mode allows use of the speaker drivers for external signals. The signal between the MIC and MIC_REF pins will pass through the AGC, the filter and the speaker drivers to the speaker outputs SP+ and SP-. The input FT controls the feed through mode. To operate this mode, the control pins REC, PLAYE and PLAYL are held low at VSS. The pin FT is held high to VCC. For normal operation of record, play and power down, the FT pin is held at VSS. The FT pin has a weak pull down to VSS.

SPECIFICATIONS

Table 1: Absolute Maximum Ratings¹

Condition	Value
Junction temperature	150°C
Storage temperature range	-65°C to +150°C
Voltage applied to any pad	($V_{SS} - 0.3$ V) to ($V_{CC} + 0.3$ V)
$V_{CC} - V_{SS}$	-0.3 V to +7.0 V

1. Stresses above those listed may cause permanent damage to the device. Exposure to the absolute maximum ratings may affect device reliability. Functional operation is not implied at these conditions.

Table 2: Operating Conditions

Condition	Value
Operating temperature range	0°C to +50°C
Play voltage (V_{CC}) ⁽¹⁾	+2.7V to +4.5V
Ground voltage (V_{SS}) ⁽²⁾	0 V
Record Supply voltage (V_{CC}) ⁽¹⁾	+2.7V to 4.5V

1. $V_{CC} = V_{CCA} = V_{CCD}$.

2. $V_{SS} = V_{SSA} = V_{SSD}$.

Table 3: DC Parameters

Symbol	Parameters	Min ⁽²⁾	Typ ⁽¹⁾	Max ⁽²⁾	Units	Conditions
V _{IL}	Input Low Voltage			0.8	V	
V _{IH}	Input High Voltage	2.0			V	
V _{OL}	Output Low Voltage			0.4	V	I _{OL} = 4.0 mA ⁽³⁾
V _{OH}	Output High Voltage	2.4			V	I _{OH} = - 1.6 mA ⁽³⁾
I _{CC}	V _{CC} Current (Operating)			30	mA	V _{CC} = 4.5V
I _{SB}	V _{CC} Current (Standby)		0.5	10	μA	⁽⁴⁾ ⁽⁵⁾
I _{ILPD1}	Input Leakage Current			±1	μA	Force V _{SS} ⁽⁶⁾
I _{ILPD2}	Input Current HIGH	30	150	400	μA	Force V _{CC} ⁽⁷⁾
I _{ILPD3}	Input Current HIGH	3		130	μA	Force V _{CC} ⁽⁸⁾
R _{EXT}	Output Load Impedance	8			Ω	Speaker Load, SP+ to SP-
R _{MIC} , R _{MICREF}	Preamp Input Resistance		10		KΩ	
A _{MSP}	MIC SP+/- Gain		42		dB	AGC = 0.0 V

1. Typical values @ T_A = 25°C and 3.0 V.
2. All Min/Max limits are guaranteed by ISD via electrical testing or characterization. Not all specifications are 100 percent tested.
3. Record LED output, RECL_{ED}.
4. V_{CCA} and V_{CCD} connected together.
5. REC, PLAYL, PLAYE, XCLK, and FT must be at V_{SSD}.
6. REC, PLAYL, and PLAYE.
7. REC, PLAYL and PLAYE.
8. FT.

Table 4: AC Parameters¹

Symbol	Characteristic	Min ⁽³⁾	Typ ⁽²⁾	Max ⁽³⁾	Units	Conditions
F _S	Sampling Frequency		6.4		KHz	⁽⁴⁾
F _{CF}	Filter Pass Band		2.6		KHz	3 dB Roll-Off Point ⁽⁵⁾⁽⁶⁾
T _{REC}	Record Duration	10		11	sec	⁽⁴⁾
T _{PLAY}	Playback Duration	10		11	sec	⁽⁴⁾
T _{EOM}	EOM Pulse Width		84		msec	
T _{DB}	Debounce Time		84		msec	

Table 4: AC Parameters¹

Symbol	Characteristic	Min ⁽³⁾	Typ ⁽²⁾	Max ⁽³⁾	Units	Conditions
THD	Total Harmonic Distortion		1		%	@ 1 KHz, $V_{IN} = 15$ mV Peak to Peak
P_{OUT}	Speaker Output Power		24.4		mW	$R_{EXT} = 8 \Omega$
V_{OUT}	Voltage Across Speaker Pins		1.25	2.5	V p-p	$R_{EXT} = 600 \Omega$
V_{IN}	MIC Input Voltage		15	300	mV	Peak-to-Peak ⁽⁷⁾

1. These specifications apply with R_{OSC} equaling 100 K Ω .
2. Typical values @ $T_A = 25^\circ\text{C}$ and 3.0 V.
3. All Min/Max limits are guaranteed by ISD via electrical testing or characterization. Not all specifications are 100 percent tested.
4. Oscillator stability may vary as much as ± 5 percent over the operating temperature and voltage ranges.
5. Low-frequency cutoff depends upon value of external capacitors (see Pin Descriptions).
6. Filter specification applies to the antialiasing filter and to the smoothing filter.
7. Balanced input signal applied between MIC and MIC REF as shown in the application example. Single-ended MIC or MIC REF recommended to be less than 100 mV peak to peak.

Figure 2: ISD1810 Application Example—Design Schematic

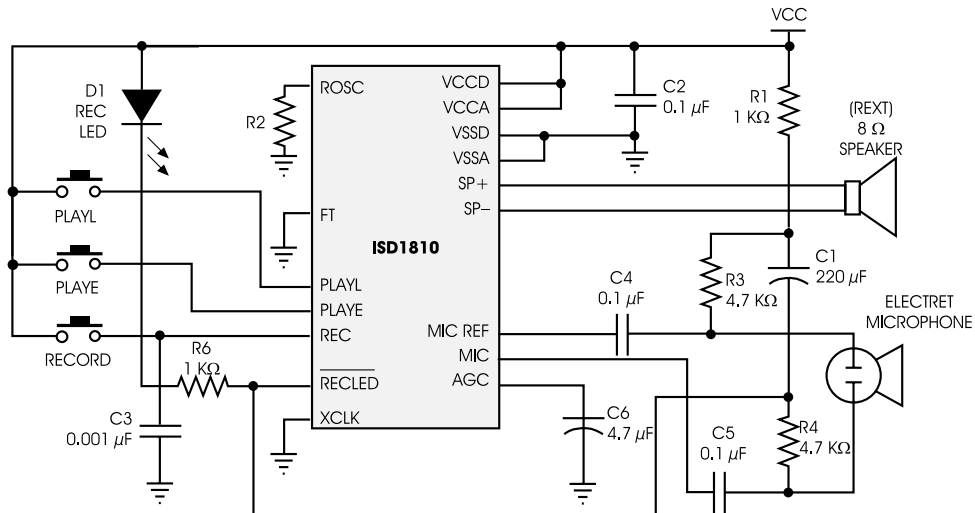

FUNCTIONAL DESCRIPTION EXAMPLE

The following example operating sequence demonstrates the functionality of the ISD1810 devices.

1. Record a message filling the memory.

Pulling the REC pin HIGH initiates a record cycle from the beginning of the message space. The device will automatically power down after REC is released LOW. An EOM marker is written at the end of message. If REC is held HIGH, the recording continues until the message space has been filled. Once the message space is filled, recording ceases.

2. Edge-activated playback.

Pulling the PLAYE pin HIGH initiates a playback cycle from the beginning of the message space. The falling edge of PLAYE has no effect on operation. When the device reaches the EOM marker, it automatically powers down. If a recording has filled the message space, the entire message is played. A subsequent rising edge on PLAYE initiates a new play cycle from the beginning of the memory.

3. Level-activated playback.

Pulling the PLAYL pin HIGH initiates a playback cycle from the beginning of the message space. When the device reaches the EOM marker, it automatically powers down. If recording has filled the message space, the entire message is played. A subsequent rising edge on PLAYL initiates a new play cycle from the beginning of the memory.

4. Level-activated playback (truncated).

If PLAYL is pulled LOW any time during the playback cycle, the device stops playing and enters the power-down mode. A subsequent rising edge on PLAYL initiates a new play cycle from the beginning of memory.

5. Record (interrupting playback).

The REC pin takes precedence over other operations. Any HIGH-going transition on REC initiates a new record operation from the beginning of the memory, regardless of any current operation in progress.

6. Record a message, partially filling the memory.

A record operation need not fill the entire memory. Releasing the REC pin LOW before filling the message space causes the recording to stop and an EOM marker to be placed. The device powers down automatically.

7. Play back a message that partially fills the memory.

Pulling the PLAYE or PLAYL pin HIGH initiates a playback cycle. The playback cycle ceases when the EOM marker is encountered and the device then powers down.

8. $\overline{\text{RECLED}}$ operation.

The $\overline{\text{RECLED}}$ output pin provides an active-LOW signal which can be used to drive an LED as a "record-in-progress" indicator. It returns to a HIGH state when the REC pin is released LOW or when the recording is completed due to the memory being filled. This pin also pulses LOW to indicate the end of a message has been reached.

9. ROSC Operation

The duration of the device can be varied by changing the value of R2 (R_{OSC}). This means the ISD1810 device can actually be between 8 to 16 seconds duration. See the curve below which charts typical durations when the R_{OSC} is varied from 80 K Ω to 160 K Ω .

This feature allows frequency shifting where a recorded voice or sound can be played back faster or slower than normal for special effects. For example, use a 100 K Ω resistor to make the recording and then

playback with either an 80 K Ω resistor for faster “chipmunk” talk or with a 120 K Ω resistor for a slower, lower voice.

Another feature is a “Pause” or interrupt function that can be done by taking the R_{OSC} resistor to V_{CC} to stop playback momentarily, resuming when the resistor is connected back to ground.

Chart 1: ISD1810 Duration versus R_{OSC} at T_A = 25°C and 3.0 V

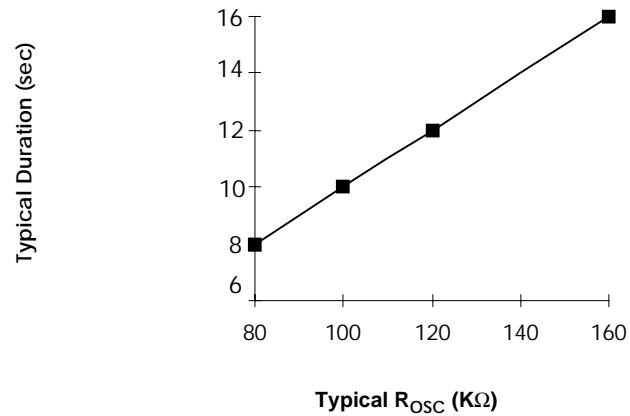

TIMING DIAGRAMS

Figure 3: Record Message Until Record Goes LOW

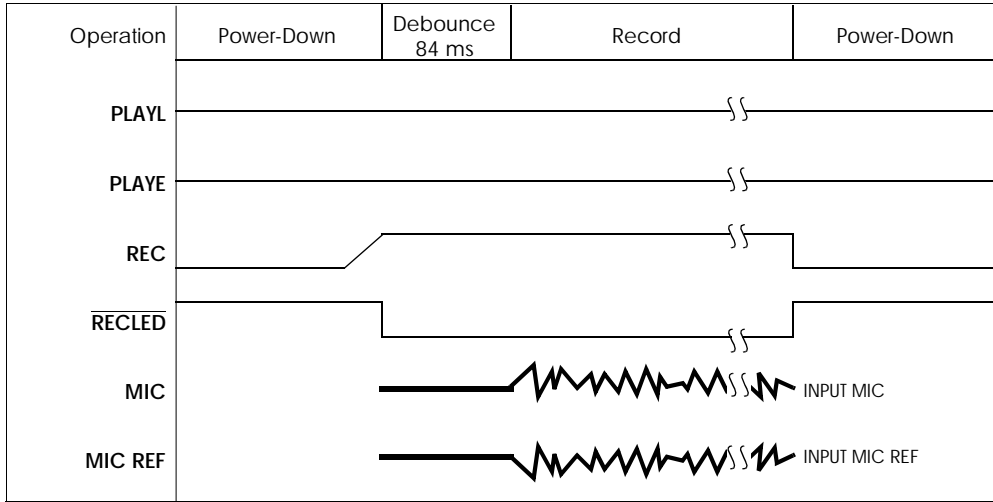

Figure 4: Record Message Until Array is Full

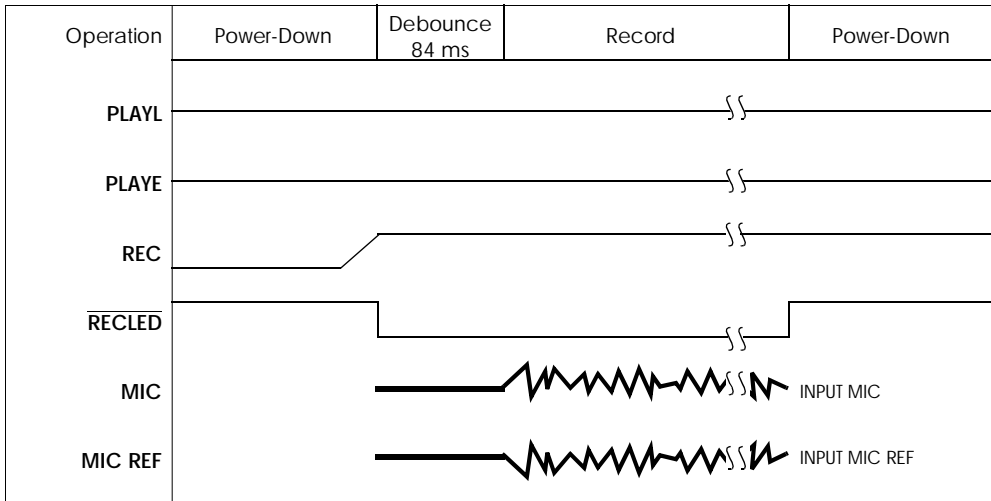

Figure 5: Play Edge (PLAYE) Play Until End of Message

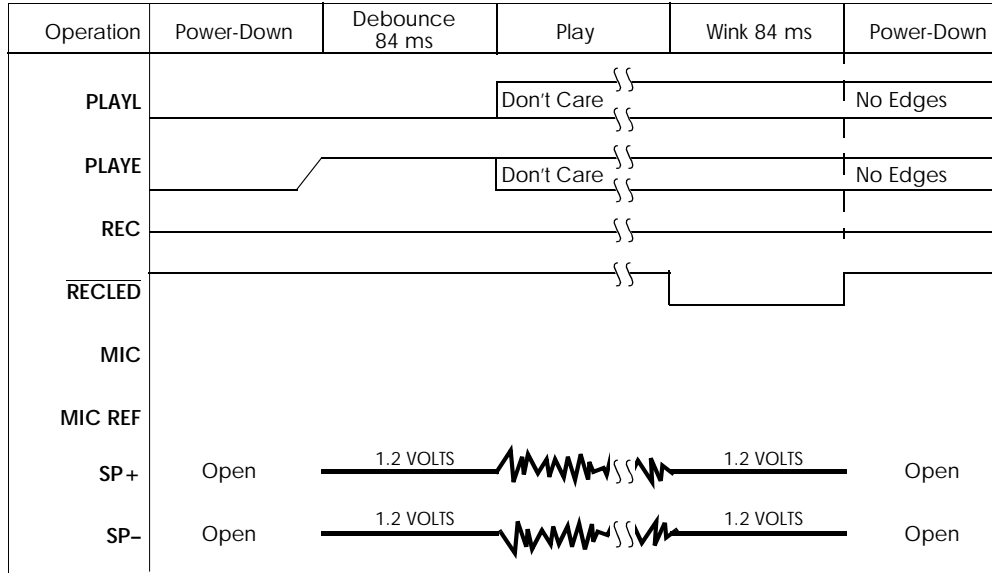

Figure 6: Play Level (PLAYL) Play Until End of Message

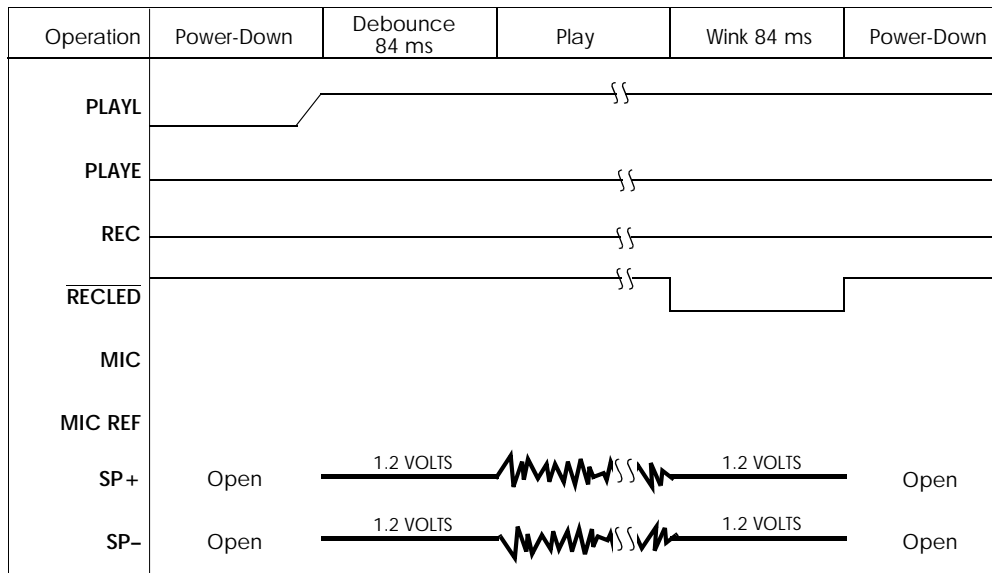

Figure 7: Play Until Play Level (PLAYL) Falls

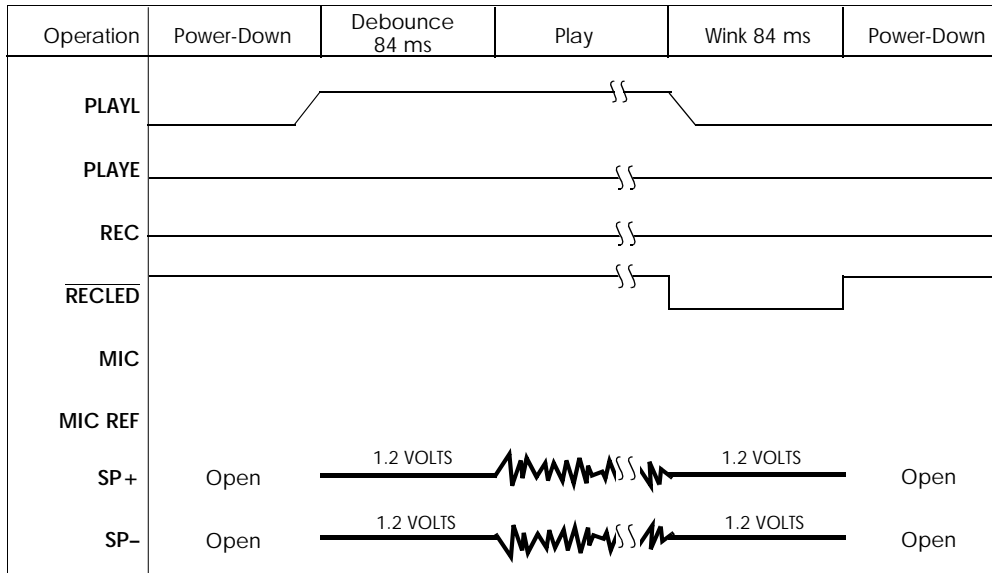
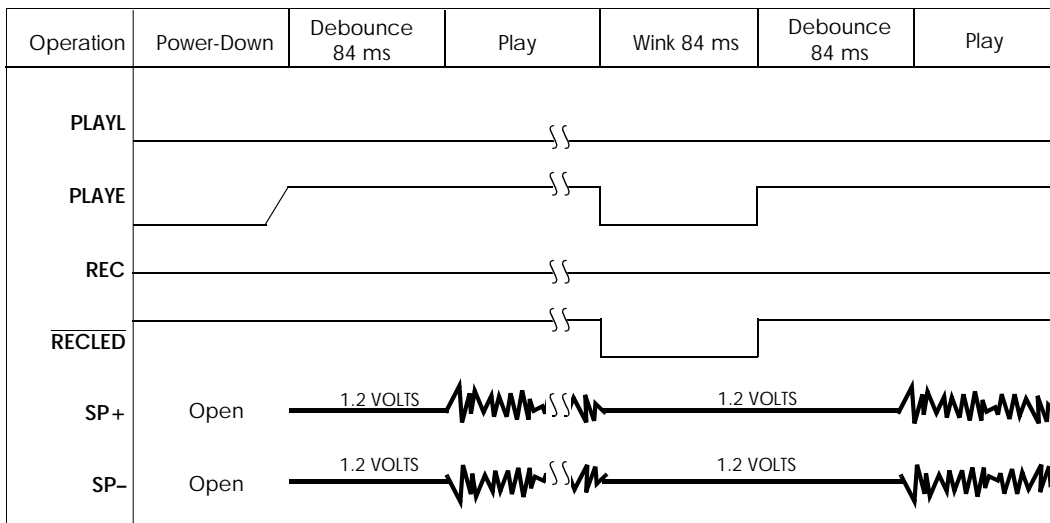

Figure 8: Looping Play, PLAYE to RECLED



PHYSICAL DIMENSIONS

Figure 9: 28-Lead 0.600-Inch Plastic Dual Inline Package (PDIP) (P)—For Sampling Only

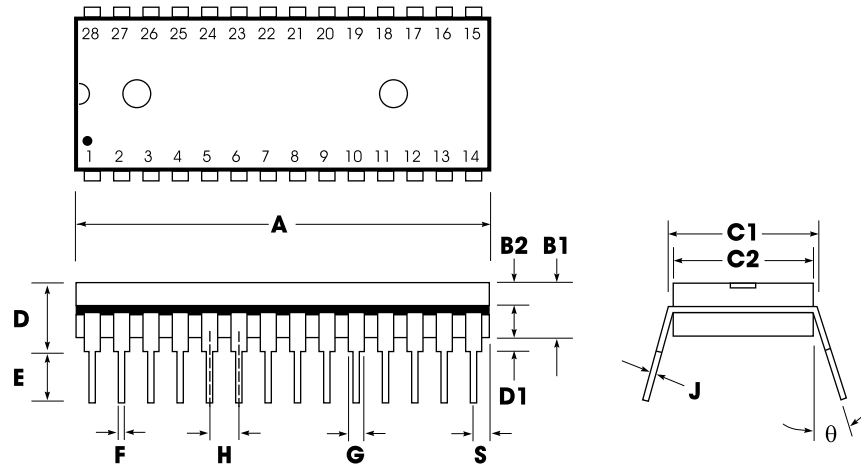

Table 5: Plastic Dual In-line Package (PDIP) (P) Dimensions—For Sampling Only

	INCHES			MILLIMETERS		
	Min	Nom	Max	Min	Nom	Max
A	1.445	1.450	1.455	36.70	36.83	36.96
B1		0.150			3.81	
B2	0.065	0.070	0.075	1.65	1.78	1.91
C1	0.600		0.625	15.24		15.88
C2	0.530	0.540	0.550	13.46	13.72	13.97
D			0.19			4.83
D1	0.015			0.38		
E	0.125		0.135	3.18		3.43
F	0.015	0.018	0.022	0.38	0.46	0.56
G	0.055	0.060	0.065	1.40	1.52	1.65
H		0.100			2.54	
J	0.008	0.010	0.012	0.20	0.25	0.30
S	0.070	0.075	0.080	1.78	1.91	2.03
q	0°		15°	0°		15°

Figure 10: ISD1810 Bonding Physical Layout (Unpackaged Die)

ISD1810

- I. Die Dimensions
 - X: 2530 mils (64,260µm)
 - Y: 2420 mils (61,470µm)
- I. Die Thickness²
 - 11.5 ±0.5 mil (typ)
- I. PAD Opening
 - 90 x 90 microns

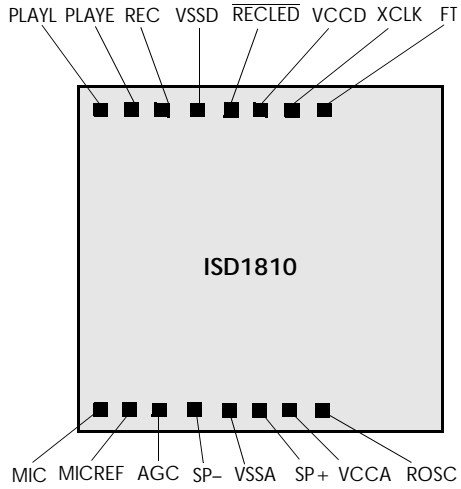

1. The backside of die is internally connected to V_{SS} . It **MUST NOT** be connected to any other potential or damage may occur.
2. Die thickness is subject to change, please contact ISD factory for status and availability.

Table 6: ISD1810 PIN/PAD Designations with Respect to Die Center

PIN	PIN Name	X Axis (μm)	Y Axis (μm)
1	VSSD	-368.95	1038.70
2	REC	-558.95	1038.70
3	PLAYE	-760.15	1038.70
4	PLAYL	-977.35	1038.70
5	N/C		
6	N/C		
7	N/C		
8	N/C		
9	N/C		
10	MIC	-977.75	-1037.20
11	N/C		
12	MIC REF	-741.75	-1037.20
13	AGC	-522.35	-1037.20
14	NC		
15	SP-	-148.15	-1024.10
16	VSSA	158.85	-1037.20
17	SP+	465.85	-1024.10
18	VCCA	772.85	-1037.20
19	ROSC	1007.85	-1037.20
20	N/C		
21	N/C		
22	N/C		
23	N/C		
24	N/C		
25	FT	630.45	1018.90
26	XCLK	358.35	1038.70
27	VCCD	122.15	1038.70
28	$\overline{\text{RECLD}}$	-126.05	1038.70

ORDERING INFORMATION

Product Number Descriptor Key

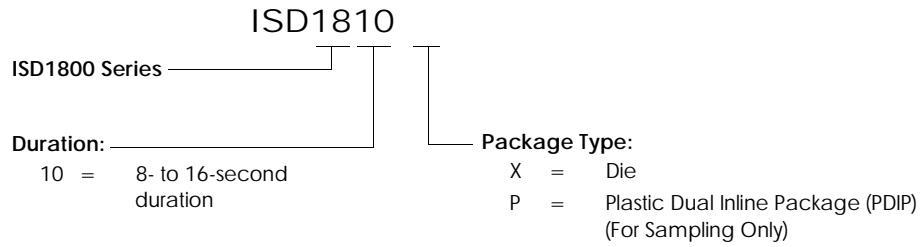

When ordering, please refer to the following part numbers which are supported in volume for this product series. Consult the local ISD Sales Representative or Distributor for availability information.

Part Number
ISD1810X
ISD1810P (For Sampling Only)

For the latest product information, access ISD's worldwide website at <http://www.isd.com>.

IMPORTANT NOTICES

The warranty for each product of ISD (Information Storage Devices, Inc.), is contained in a written warranty which governs sale and use of such product. Such warranty is contained in the printed terms and conditions under which such product is sold, or in a separate written warranty supplied with the product. Please refer to such written warranty with respect to its applicability to certain applications of such product.

These products may be subject to restrictions on use. Please contact ISD, for a list of the current additional restrictions on these products. By purchasing these products, the purchaser of these products agrees to comply with such use restrictions. Please contact ISD for clarification of any restrictions described herein.

ISD, reserves the right, without further notice, to change the ISD ChipCorder product specifications and/or information in this document and to improve reliability, functions and design.

ISD assumes no responsibility or liability for any use of the ISD ChipCorder products. ISD conveys no license or title, either expressed or implied, under any patent, copyright, or mask work right to the ISD ChipCorder products, and ISD makes no warranties or representations that the ISD ChipCorder products are free from patent, copyright, or mask work right infringement, unless otherwise specified.

Application examples and alternative uses of any integrated circuit contained in this publication are for illustration purposes only and ISD makes no representation or warranty that such applications shall be suitable for the use specified.

The ISD products described herein may not be used in recordable greeting cards intended for resale in Japan without ISD's prior written consent. Recordable greeting cards are articles, usually constructed of paper or cardboard (but not limited to these materials), that include artwork (including preprinted or customer-affixed photographs or artwork) and/or editorials that have the look and feel of greeting cards and are

able to be inserted into an envelope (but do not necessarily need to be inserted) and primarily intended to be presented or delivered to an individual as a greeting card, that allow the sender to record and the recipient to play back, and audio signal message. The foregoing restriction applies only to recordable greeting cards intended, directly or indirectly, for retail distribution. Recordable greeting cards incorporating ISD products may not be sold, directly or indirectly, through retail channels without ISD's prior written consent.

The 100-year retention and 100K record cycle projections are based upon accelerated reliability tests, as published in the ISD Reliability Report, and are neither warranted nor guaranteed by ISD.

Information contained in this ISD ChipCorder data sheet supersedes all data for the ISD ChipCorder products published by ISD prior to August, 1998.

This data sheet and any future addendum to this data sheet is (are) the complete and controlling ISD ChipCorder product specifications. In the event any inconsistencies exist between the information in this and other product documentation, or in the event that other product documentation contains information in addition to the information in this, the information contained herein supersedes and governs such other information in its entirety.

Copyright© 1998, ISD (Information Storage Devices, Inc.) All rights reserved. ISD is a registered trademark of ISD. ChipCorder is a trademark of ISD. All other trademarks are properties of their respective owners.



2727 North First Street
San Jose, California 95134
Tel: 408/943-6666
Fax: 408/544-1787
<http://www.isd.com>

Part No. 2200898D1510
